

**FLOATING  
MULTIPOINT**

**PED**  **CE** **NACE**  **SIL2** Safety Integrity Level 



Via Di Vittorio 307/25 - 20099 Sesto San Giovanni (MI) - Italy  
Tel: +39.028.976.1628 - Fax: +39.028.976.2167  
[www.sestovalves.com](http://www.sestovalves.com) - [sales@sestovalves.com](mailto:sales@sestovalves.com)



## Features and Benefits

- Class 150 to Class 800
- Size Range ½" thru 4" (Class Dependent)
- Custom Sizes by Request
- 3-Way and 4-Way Configurations (T, L, Double L)
- 4-Seat Design, Universal Inlet/Outlet
- Floating Full and Reduced Bore
- Single Body Construction (No Top Flange)
- Fire-Safe Design API 607 Available
- Blowout Proof, Low Torque Guided Stem Design
- Anti-Static Device and Live-Loaded Packing
- Fugitive Emissions ISO 15848
- Wide Range of Soft Seat and Metal Seat Options
- A105N, LF2, LF3, Forged Body Options
- Special Materials Available Upon Request

## Versatility & Reliability

The Sesto design allows for the use of all types and materials of construction and may be installed in any flow configuration and orientation. In addition, the Sesto true multiport solution is engineered with O-ring energized and self-aligning floating seats, ensuring positive shutoff in varying conditions, regardless of flow direction - any inlet can be used as an outlet. We have many different metal seated options for a variety of high temperature, corrosive, or abrasive applications. Our experienced team of engineers can design and build the right valve for your exact requirements. Our precision machined innovative design has been tested to the highest standards and may be used in virtually any application with confidence. The Sesto Floating Multiport Valve is Sil 2 certified, fire tested, FE tested, and built to last. Reliable repeat performance is our responsibility to you. It is truly a Premium Italian Valve.

## Certifications and Compliance

- Sesto Valves are designed and manufactured to internationally recognized standards including but not limited to the following:
- Testing:** API 6A, API 598, API 17D, ISO 5208, BS 6755 Part I
  - Marking:** API 6A, MSS-SP-25, PED
  - Certifications:** API607, SIL, NACE, MR0175, PED, Fugitive Emissions

## Partial List of Applications

- Lease Automatic Custody Transfer units
- Aerospace Industry
- Gas Production Facilities
- Food & Beverage
- Regasification
- Chemical Injection Skids
- Industrial Chemical Processes
- Cargo and Bunkering Systems
- Petrochemical Plants

## End Connections

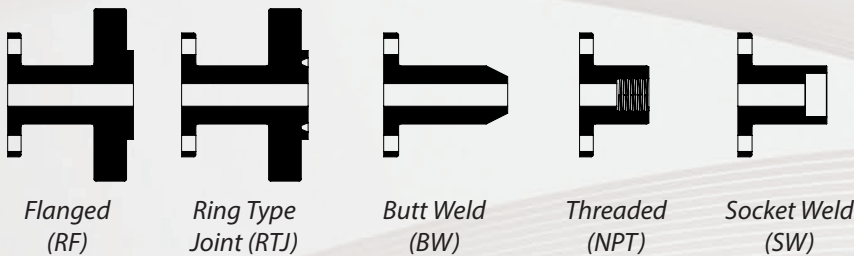

150# to 800#  
½" thru 4"



## Why Sesto?

Sesto Multiport Design	The Sesto Difference
Precision Machined Forged Body	The forged body eliminates the possibility of leakage due to poor castings. Precision finish machining keeps tight tolerances to ensure secure assembly for high pressure, critical applications.
4-Seat Design Standard	The 4-Seat design effectively isolates the main body cavity from process pressure, minimizing internal leakage and ensuring proper sealing regardless of flow direction.
Ball/Seat Lapping	Lapping seats to the ball ensures tight tolerances, improving shut-off sealing capability while lowering torque requirements.
Application Specific Testing Protocol	We build upon proven API 598 testing standards and customize our testing protocols to simulate actual service pressure conditions, guaranteeing valve performance before field installation.
Self-Aligning O-Ring Energized Seats	The self-aligning floating seat design allows for flexibility in materials of construction (end closures vs. seats vs. body), and ease of maintenance. This design also ensures positive shutoff between sealing components to improve sealing performance in varying conditions.

## Floating Multiport Design

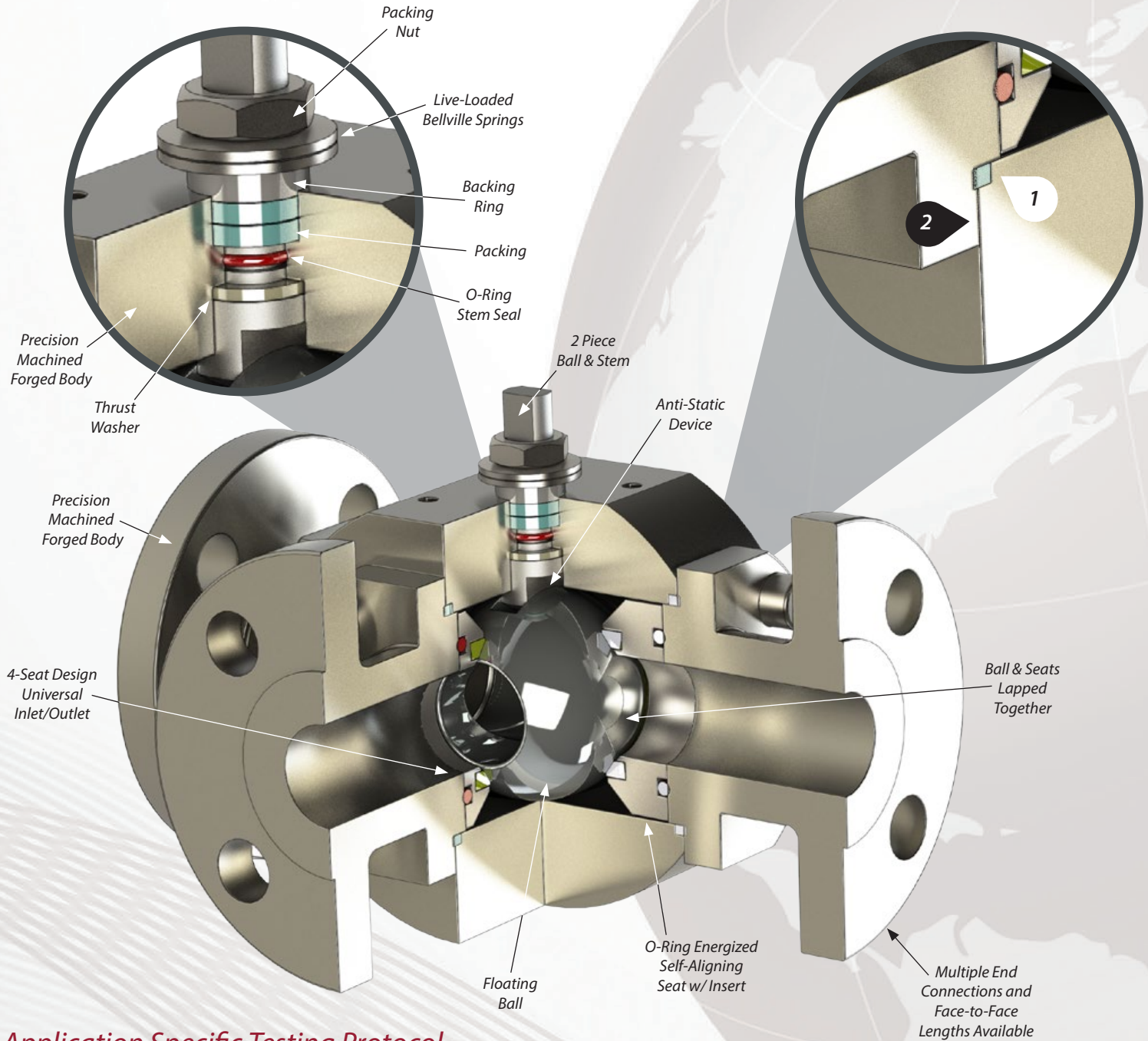

## Application Specific Testing Protocol

To test the efficacy of multiport ball valve design and performance, Sesto Valves has developed detailed testing protocols that go above and beyond current industry practice. Standard production tests do not always accurately simulate the conditions for the varying scenarios of real world multiport valve applications. Additionally, there currently are no industry standards that govern the construction and testing of multiport valves. As such, portions of other standards need to be appropriately applied to these valves to assure valve integrity and performance in actual conditions. With the API 598 standard as the foundation, Sesto Valves builds upon this to customize multiport testing protocol according to an understanding of specific application requirements. Sesto Valves believes that using proven testing standards and applying them in the context of actual service conditions is the best way to accurately test multiport valves.



**Self-Aligning O-Ring Energized Seats**

Self-Aligning Floating 4-Seat Design isolates pressure from the center cavity and reduces torque.

**Double Body Seal**

(Providing Two Levels of Defense)

**1. Primary Body Seal (RPTFE)**

Soft seal for reliable sealing at all pressures

**2. Backup Metal-to-Metal Interface**

Forms a labyrinth seal with a torturous flow path.

**Ball/Seat Lapping**

All Sesto Multiport Ball Valves utilize lapped ball and seat sets. This precise manufacturing process ensures the lowest operating torque and the tightest possible sealing capability of the ball and seats, while at the same time providing for an extremely long service life for the intended application. Lapping is a surface polishing process where compounded powders are used as the lapping agent to achieve a matched fit.

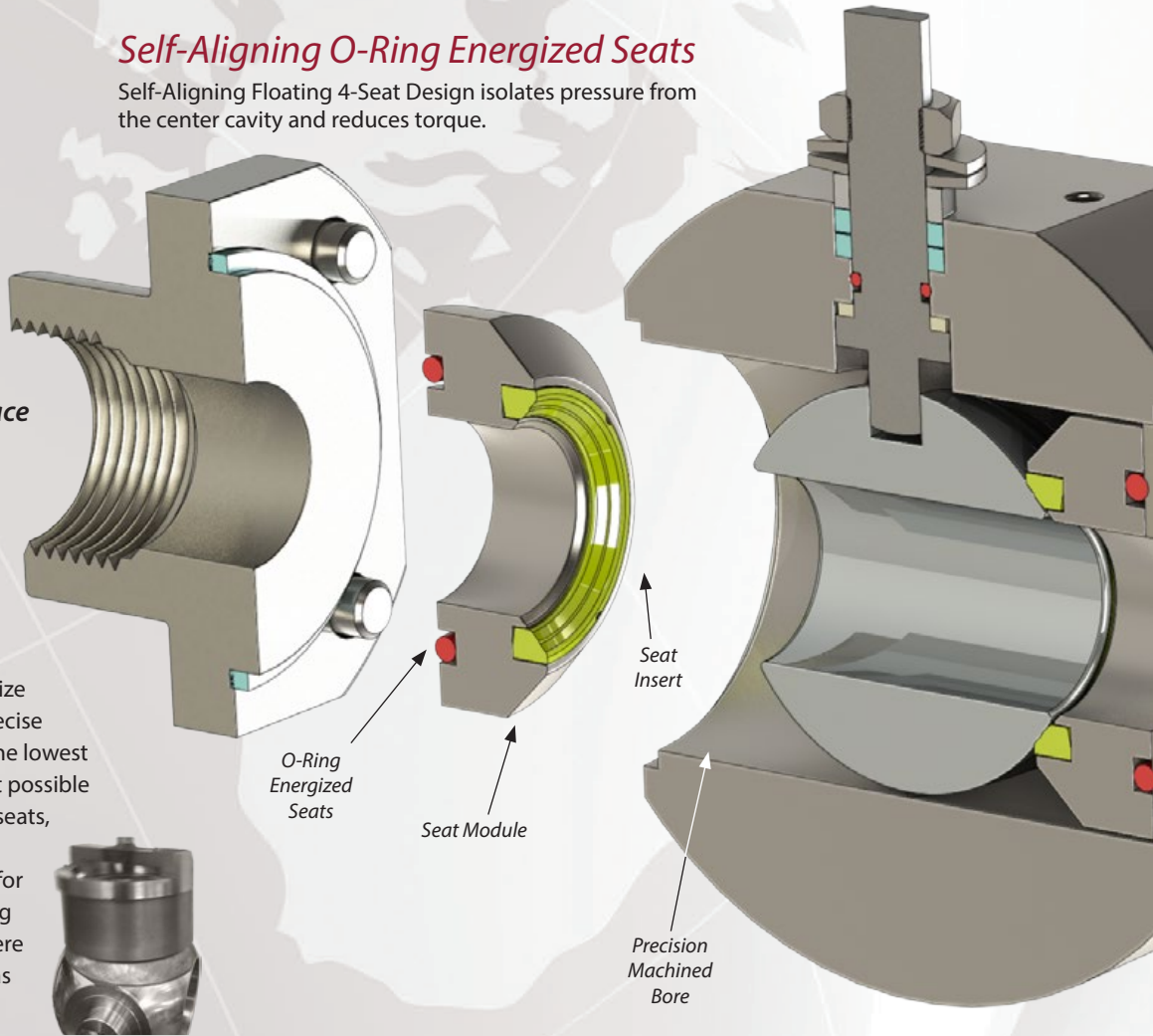

**Sesto Valves Exclusive**

Self Aligning 4-Seat Design, Seats Energize Any Direction | +Universal Inlet/Outlet Design

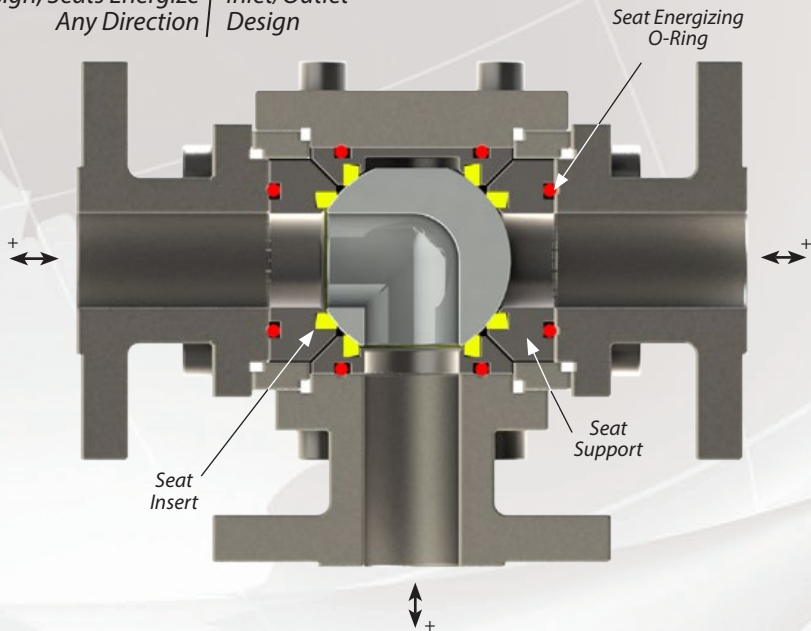

**4-Seat Design**

Multiport ball valve applications can present unique challenges for reliable valve sealing. With three or more ports, the valve must be able to seal in at least two different positions. To successfully achieve this requires either a designated flow direction or a seat design that allows for sealing from multiple directions, even in trunnion designs with self-relieving seats. This can be difficult - particularly for T-ported balls or floating balls - because any port could potentially be an inlet and the high-pressure source could be on either side of the ball. To realize this design, Sesto Valves has engineered seat solutions with floating, spring-energized and pressure-energized characteristics customized to each application. Valve sealing mechanics and materials are optimized to allow for reliable positive shutoff in varying conditions, regardless of flow direction.



Worldwide Headquarters  
Via Di Vittorio 307/25 - 20099 Sesto San Giovanni (MI) - Italy  
Tel: +39.028.976.1628 - Fax: +39.028.976.2167  
[www.sestovalves.com](http://www.sestovalves.com) - [sales@sestovalves.com](mailto:sales@sestovalves.com)