

TRUNNION

PED



NACE



SIL2
Safety Integrity Level

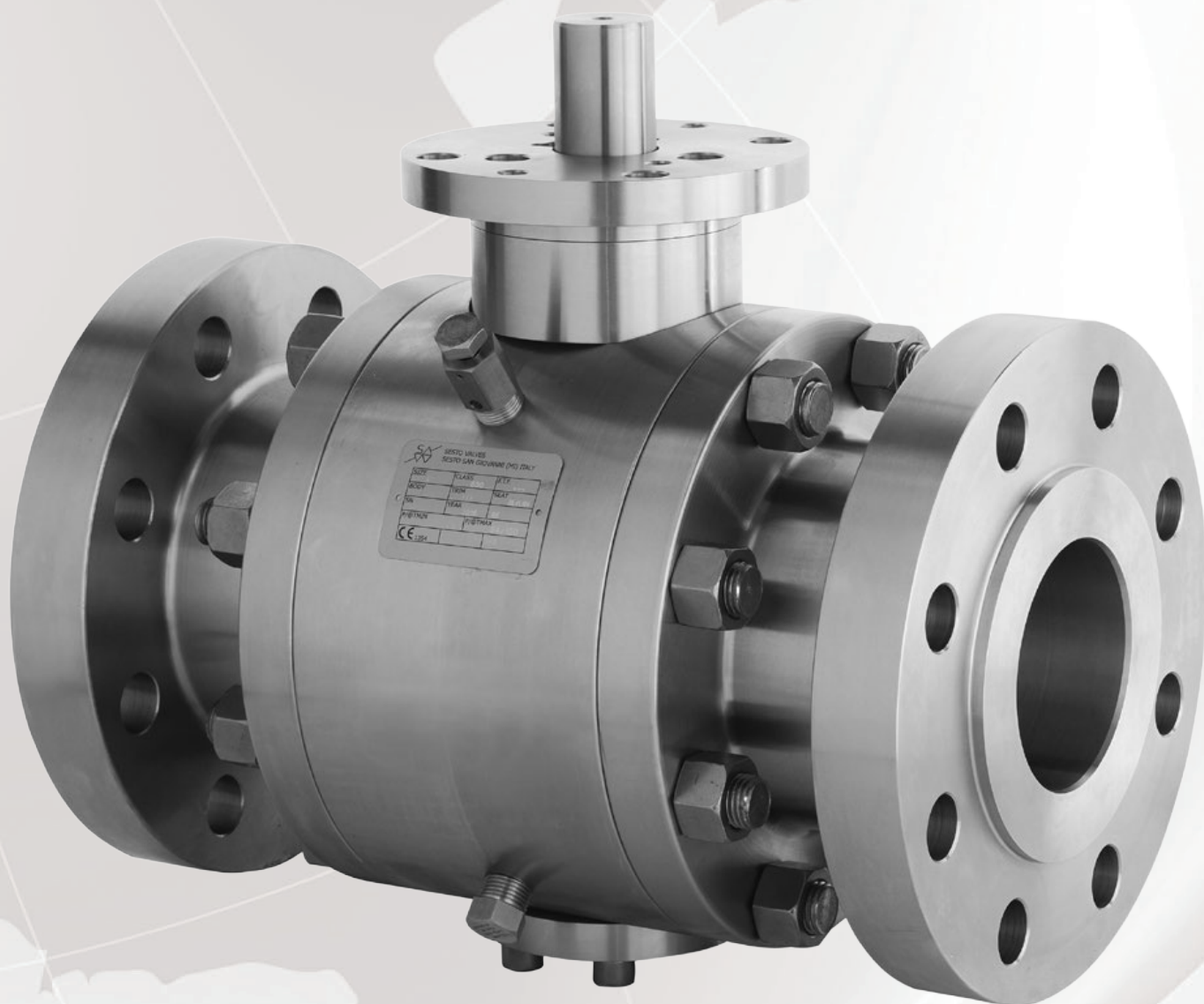

Via Di Vittorio 307/25 - 20099 Sesto San Giovanni (MI) - Italy
Tel: +39.028.976.1628 - Fax: +39.028.976.2167
www.sestovalves.com - sales@sestovalves.com

Introduction



Sesto Valves is a premium high performance ball valve manufacturer headquartered in Sesto San Giovanni, Italy. We source only the best materials from our global partners to ensure quality and competitive pricing.

Our valves are 100% manufactured and tested in Italy so we can control our product quality and provide easy traceability. Sesto Valves offers a full line-up of floating or trunnion mounted ball valves, 3-way multiport ball valves, fully welded ball valves and double-block-and-bleed ball valves suitable for any application ranging from standard duty to critical service, including exotic materials and super alloys.

Our products can be supplied as simple manual shutoff valves or with customized automation and controls for unique requirements. Focused on the chemical, petrochemical and energy industry, Sesto Valves provides solutions for exploration, production and distribution as well as a wide variety of industrial applications.



CITY OF SESTO SAN GIOVANNI



Europe

World Headquarters
Sesto SG, Italy
Via Di Vittorio 307/25
20099 Sesto SG
Italy
Tel: +39.028.976.1628
Fax: +39.028.976.2167



North America

O'Fallon, Missouri
751 Hoff Road
O'Fallon, MO 63366
United States
Tel: +1.636.272.4934
Fax: +1.636.272.4937



Asia

Jinan, China
Room 606 Tongyuan
Building, No.68
Tongyuanju Front Street,
Jinan 250012
China
Tel: +86.0531.86917039
Fax: +86.0531.86917039

Features and Benefits

Class 150 to Class 2500
 Size Range 2" thru 24" (Class Dependent)
 Full and Reduced Bore
 Body Wall Thickness ASME B16.34
 End Connections: RF, RTJ, BW, SW, NPT, BSP, Special
 Fugitive Emissions ISO 15848
 Fire-Safe Tested API 607
 Emergency Sealant Injectors Optional
 Anti-Static Device and Live-Loaded Packing
 Guided Seat Design
 Blowout Proof, Low Torque Guided Stem Design
 Wide Range of Soft and Metal Seated Options
 Manual, Electric, Pneumatic,
 or Electro-Hydraulic Operators Available
 Custom Face-to-Face Lengths Available

Versatility & Reliability

The Sesto Valves trunnion mounted ball valve design allows for the use of all types and materials of construction and may be installed in any flow configuration and orientation. Customizable spring configurations and guided seat design gives the option for a carbon steel body and end enclosures with a duplex or stainless seat module. Metal seated options are available for a variety of high temperature, corrosive, or abrasive applications. Our experienced team of engineers can design and build the right valve for your exact requirements. Sesto trunnion ball valves are Sil 2 certified, fire tested, FE tested, and built for application specific versatility and long term reliability.

End Connections



Flanged
(RF)

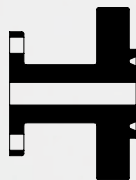

Ring Type
Joint (RTJ)

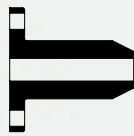

Butt Weld
(BW)



Threaded
(NPT)



Socket Weld
(SW)

150# to 2500#
2" thru 24"

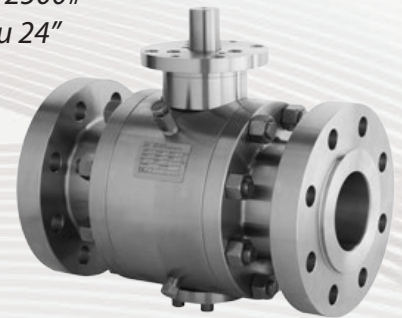

Certifications and Compliance

Sesto Valves are designed and manufactured to internationally recognized standards including but not limited to the following:

Design: API 6D

Fire Testing: API 607, API 6FA, BS 6755 Part II

Testing: API 6A, API 598, API 17D, ISO 5208, BS 6755 Part I

Marking: API 6A, MSS-SP-25, PED

Certifications: API607, SIL, NACE, MR0175, PED, Fugitive Emissions

Partial List of Applications

Oil & Gas Pipelines	Offshore Platforms
Refineries and Petrochemical Plants	HIPPS Systems
Power Generation	Cryogenic Service Applications
Gas and Coal Fired Turbines	Emergency Shut Down Valves
District Heating	Pulp & Paper
Gas Measurement Systems	Mining
	Boiler Steam and Drain Applications

Why Sesto?

Sesto Multiport Design	The Sesto Difference
Precision Machined Forged Body	The forged body eliminates the possibility of leakage due to poor castings. Precision finish machining keeps tight tolerances to ensure secure assembly for high pressure, critical applications.
Ball/Seat Lapping	Lapping seats to the ball ensures tight tolerances, improving shut-off sealing capability while lowering torque requirements.
Guided Seat Design	The guided seat design allows for flexibility in materials of construction (end closures vs. seats vs. body), customizable spring configurations for specific pressure relief set points, and ease of maintenance. This design also ensures better concentricity between sealing components to improve sealing performance.

Trunnion Design

Fire-Safe & Fugitive Emissions Certified

Packing arrangement is fire-safe for critical applications and Fugitive Emissions ISO 15848 certified.

Single or Double
Piston Effects
Available

Metal Seated (Shown)
or Soft Seated
Inserts Available

Balls and Seats
Lapped Together

Seat
Module

Precision
Machined
Bonnet

Fire-Safe
Packing

Packing
Ring

Stem
O-Ring
Seal

Thrust
Washer

Bleed
Valve

Primary &
Secondary
Body Seals

Trunnion
Mounted Ball

Drain
Valve

Custom End
Connections &
Face-to-Face
Lengths Available

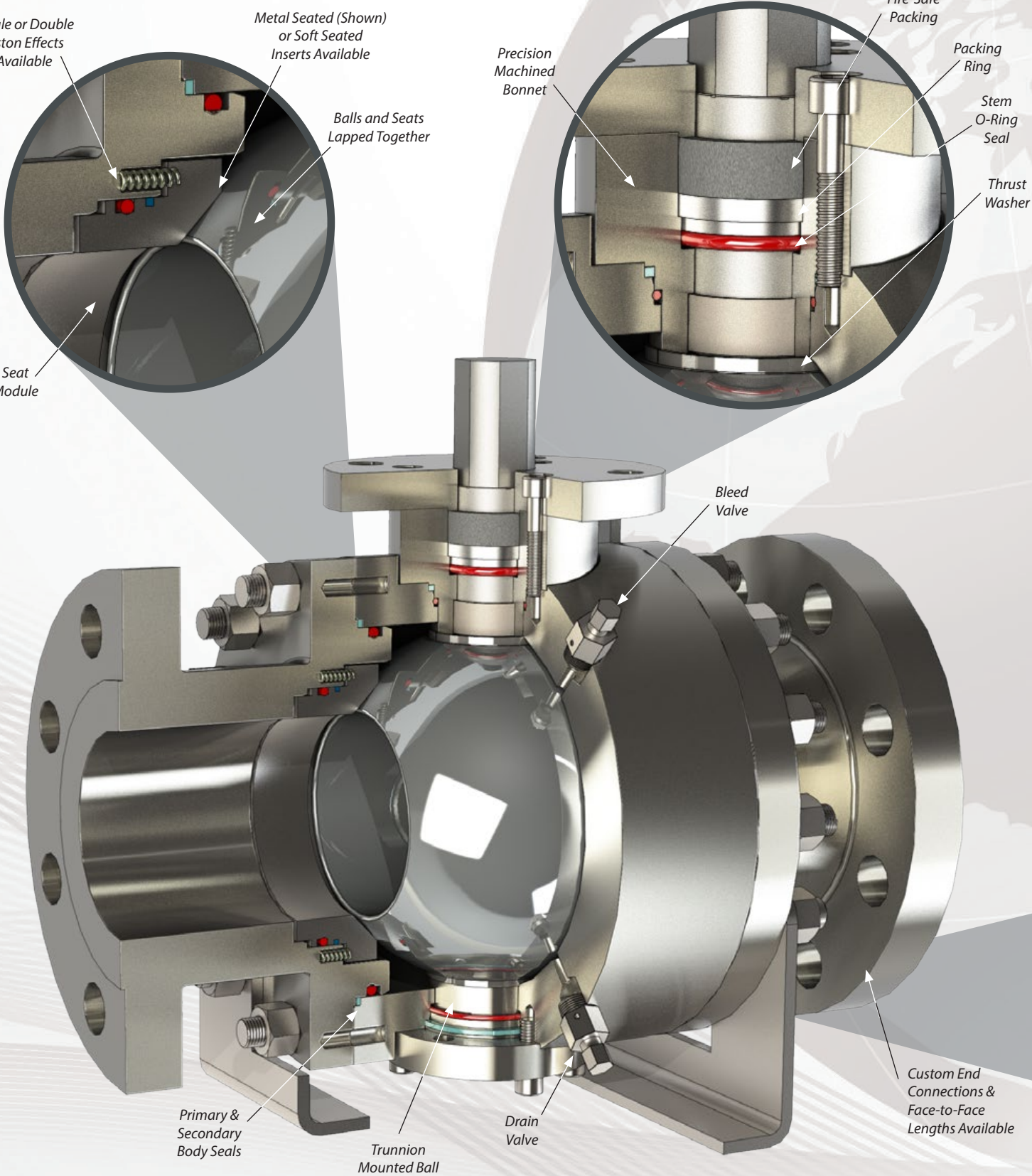

Ball/Seat Lapping

All Sesto trunnion ball valves utilize lapped ball and seat sets. This precise manufacturing process ensures the lowest operating torque and the tightest possible sealing capability of the ball and seats, while at the same time providing for an extremely long service life for the intended application. Lapping is a surface grinding/polishing process where loose abrasive powders are used as the lapping agent to achieve the extremely tight tolerances.



Guided Seat Design

Sesto Valves Guided Seat Design surrounds the seat module within the end closure, eliminating the need to seal against the center body and minimizing leak paths. The sliding seals on the seat module are no longer part of the critical body seal pathway.

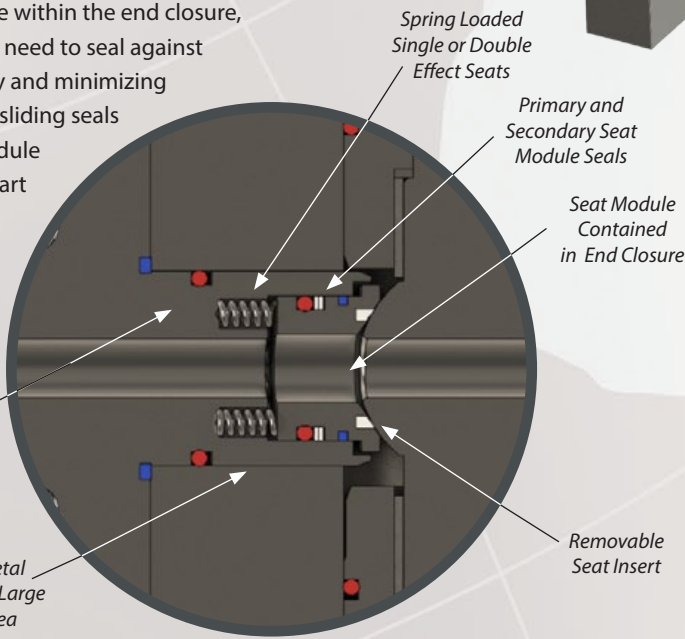

Extended End Closure
Guides Springs and Seat Module

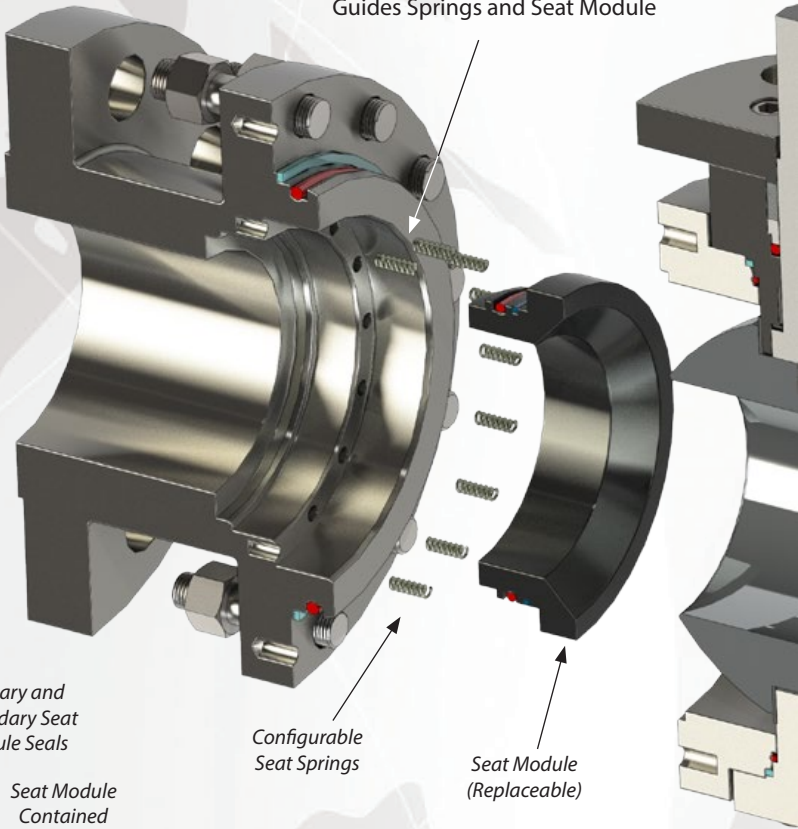

Options

- Emergency Shutdown (ESD) Valves
- Welded Body for Municipal Heating
- Cryogenic
- Metal-Seated
- Double Block and Bleed
- Double Isolation and Bleed

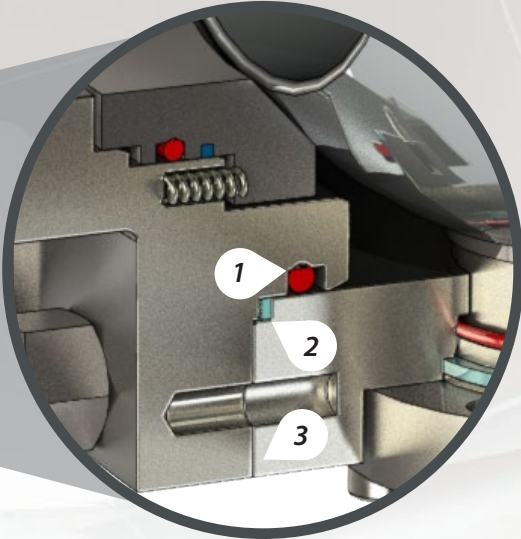

Triple Body Seal

(Providing Three Levels of Defense)

- 1. Primary Body Seal (RPTFE)**
Soft seal for reliable sealing at all pressures
- 2. Secondary Body Seal (Graphite)**
Provides a fire safe secondary seal.
- 3. Backup Metal-to-Metal Interface**
Forms a labyrinth seal with a torturous flow path.



Worldwide Headquarters
Via Di Vittorio 307/25 - 20099 Sesto San Giovanni (MI) - Italy
Tel: +39.028.976.1628 - Fax: +39.028.976.2167
www.sestovalves.com - sales@sestovalves.com